

Self-reconfigurable security-enhanced communications in FPGA-based MPSoCs

Pascal Cotret, Laboratoire Lab-STICC
Université De Bretagne-Sud
<pascal.cotret@univ-ubs.fr>

Château de Goutelas, Marcoux
June 21st, 2012



This FPGA-based SoC can be attacked !

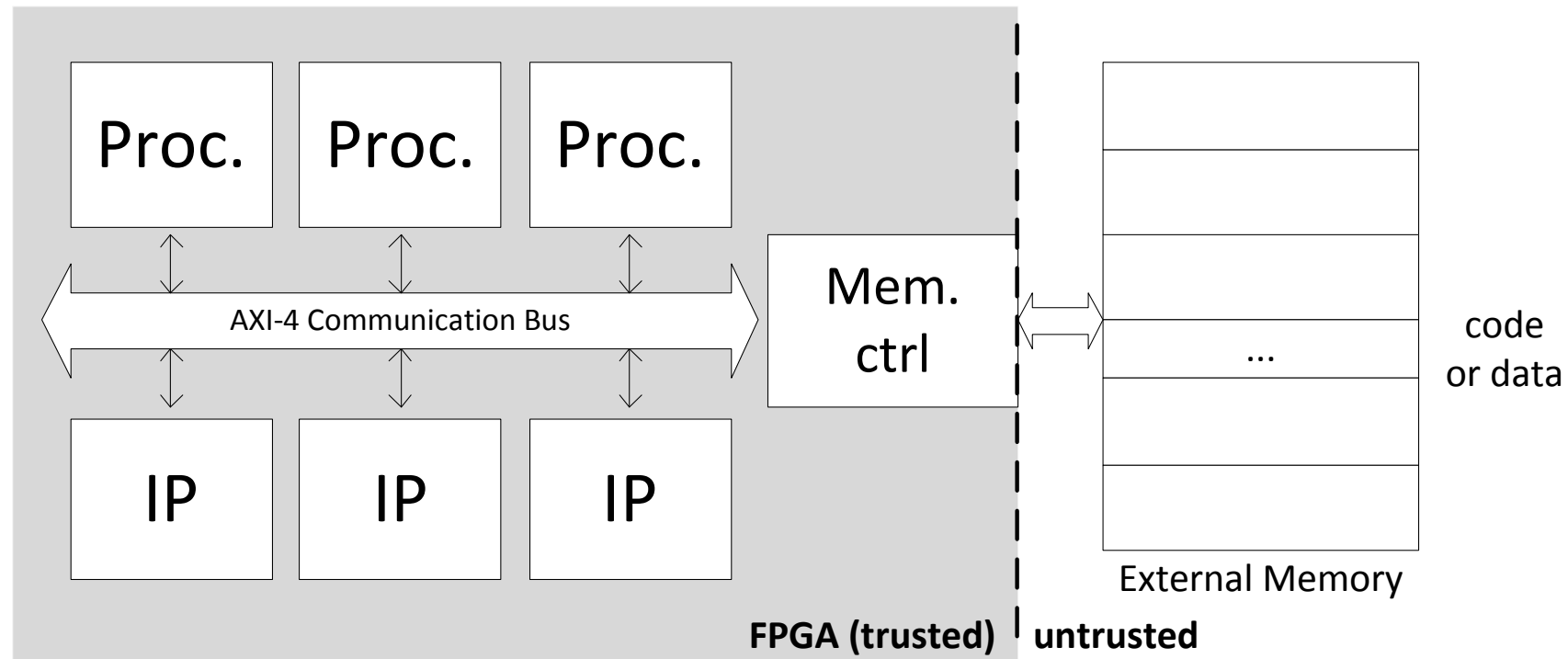

- Trusted/Untrusted areas.
- Threat model: external bus and memory.

This FPGA-based SoC can be attacked !

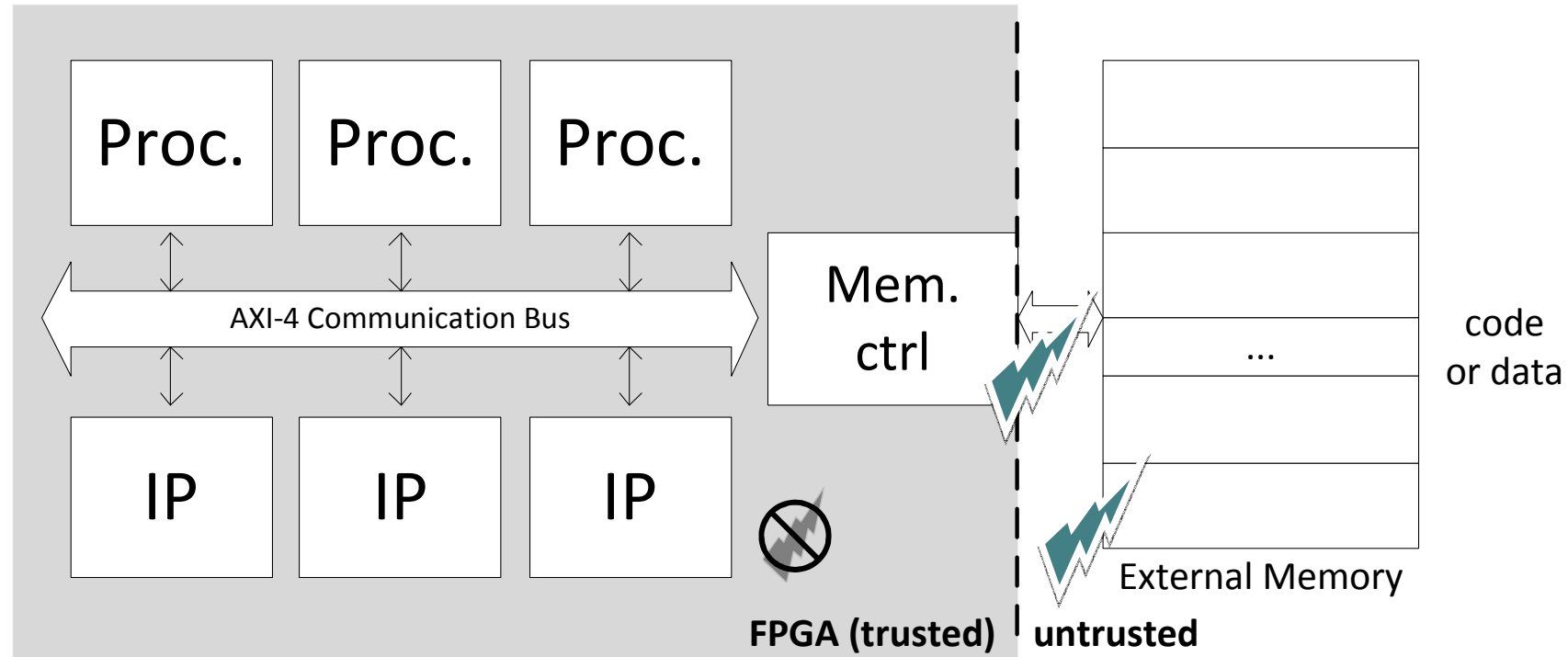

- Trusted/Untrusted areas.
- Threat model: external bus and memory.

This FPGA-based SoC can be attacked !

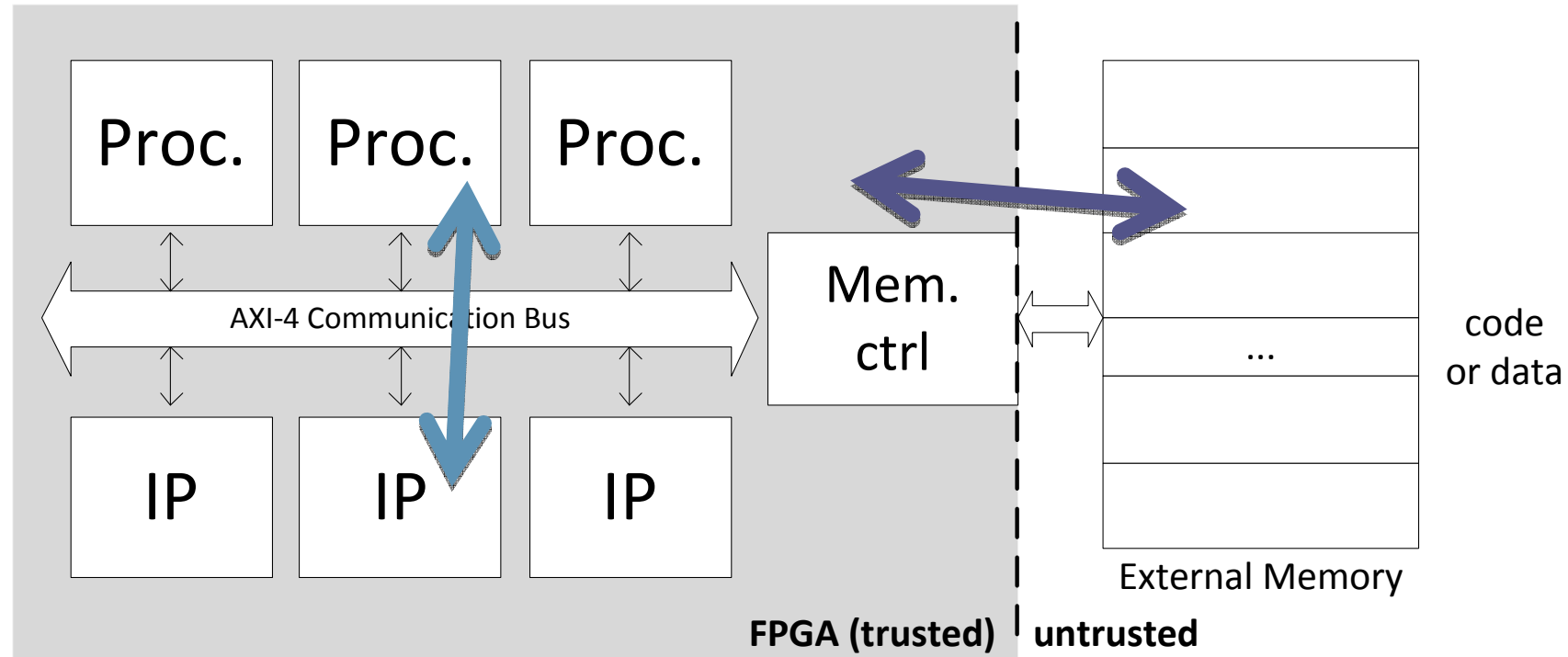

- Trusted/Untrusted areas.
- Threat model: external bus and memory.
- Two kinds of transactions: **internal** and **external**.

This FPGA-based SoC can be attacked !

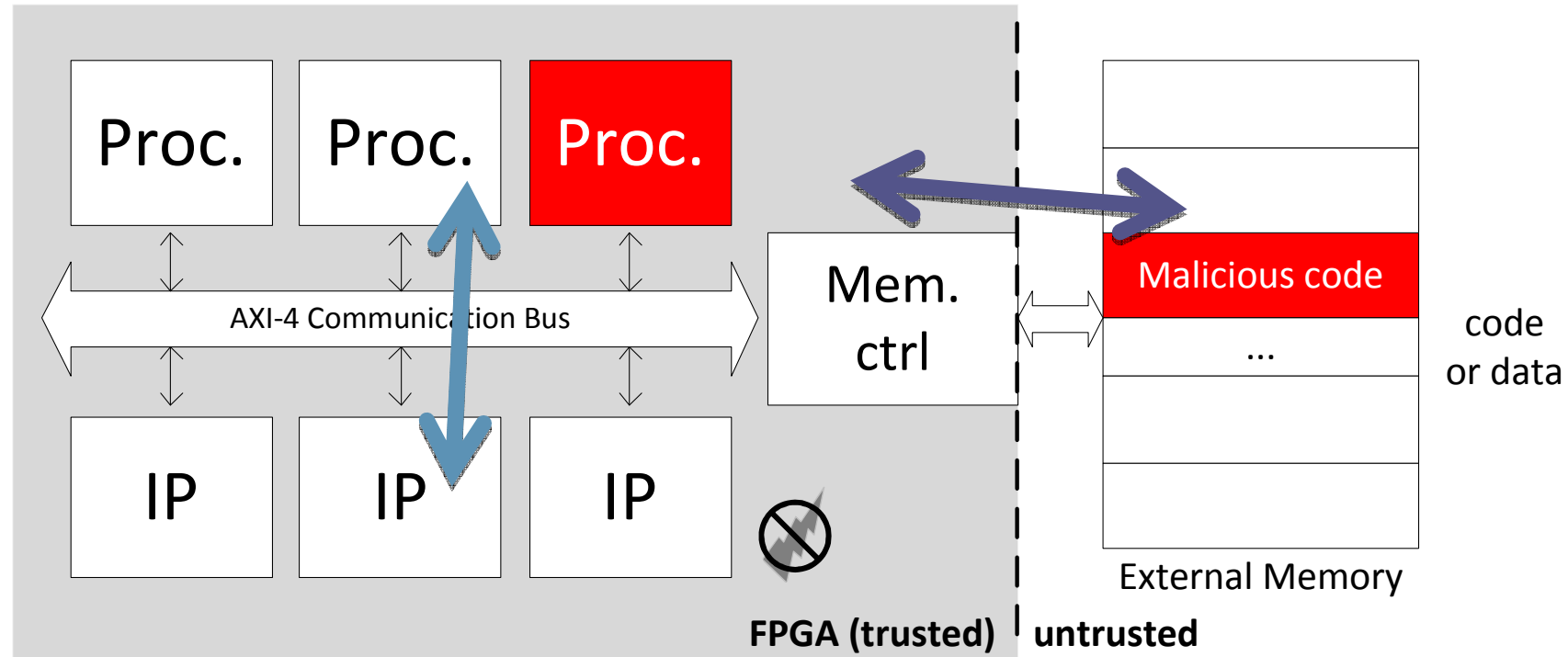

- Trusted/Untrusted areas.
- Threat model: external bus and memory.
- Two kinds of transactions: **internal** and **external**.

This FPGA-based SoC can be attacked !

- Properties to be met in **internal** transactions:
 - No illegal accesses.
- Properties to be met in **external** transactions:
 - Protection of data and code.
 - No modification.
 - Illegible contents.

Threat model for this FPGA-based SoC

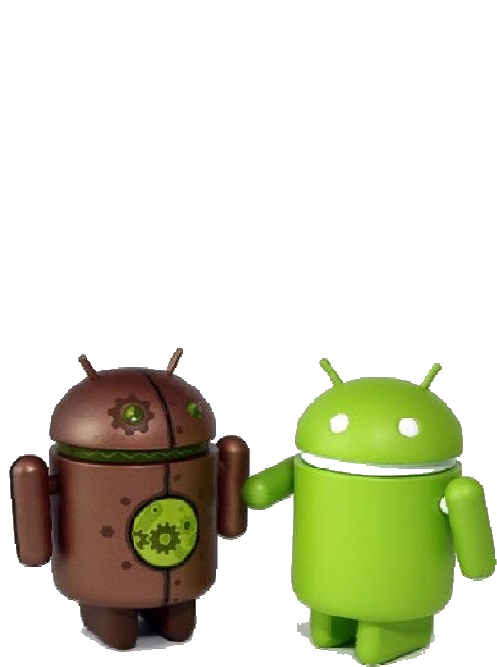

Remote software attacks
Virus, worms, Trojan horses

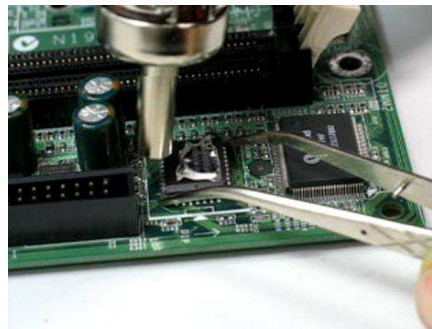

**Proximity-based
hardware attacks**
Power/EM analysis



**Reversible
proximity-based attacks**
Fault injection

Threat model is FPGA-based SoC

- Countermeasures for spoofing, replay and relocation.
- **Internal** transactions metrics:
 - Read/Write rights.
 - Memory mapping.
 - Transaction formats.
- **External** transactions metrics:
 - Confidentiality.
 - Integrity.

This FPGA-based SoC can be secured !

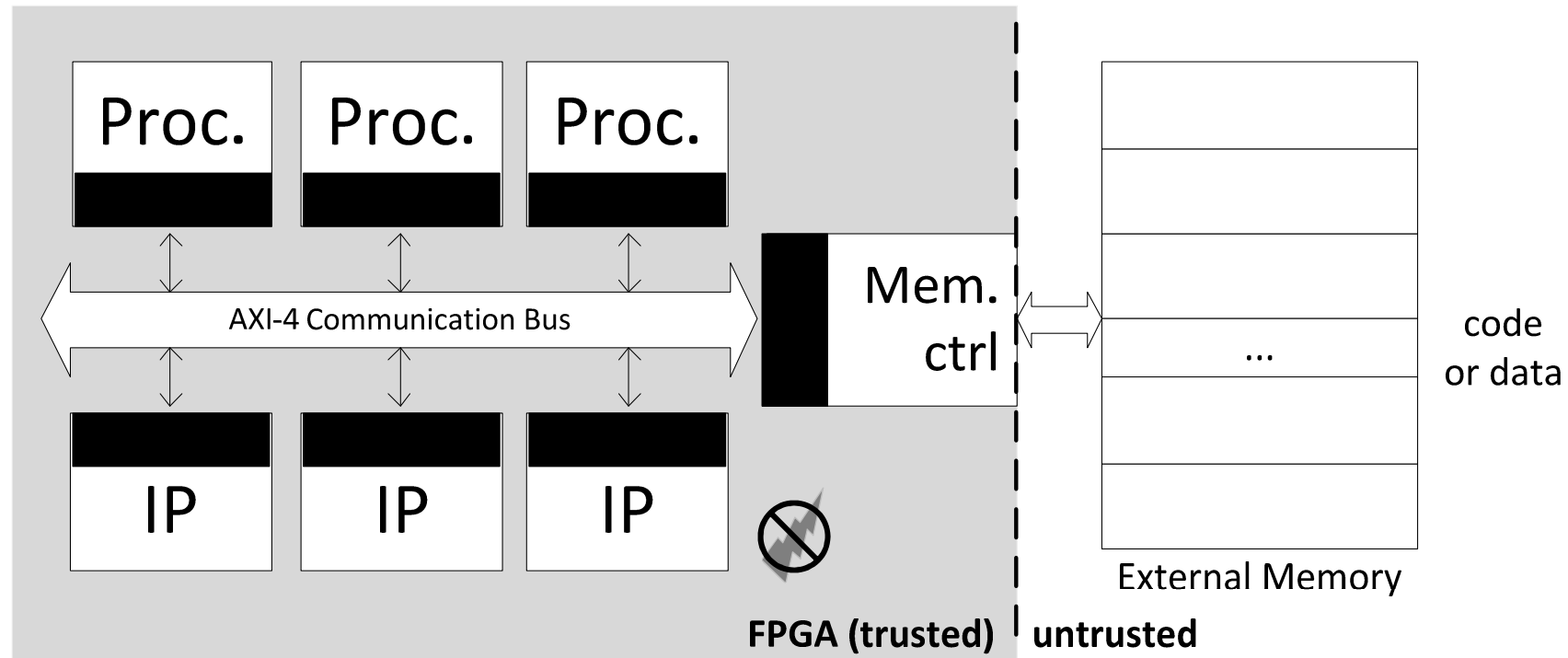

- Hardware secure-enhanced interfaces (« firewalls »).
- Goals:
 - Protection against defined threat model.
 - Low-latency feature.
 - Security updates in case of attack or new application settings.

Proposed solution in a few steps

- Static security
- Dynamic update of security rules

Static solution

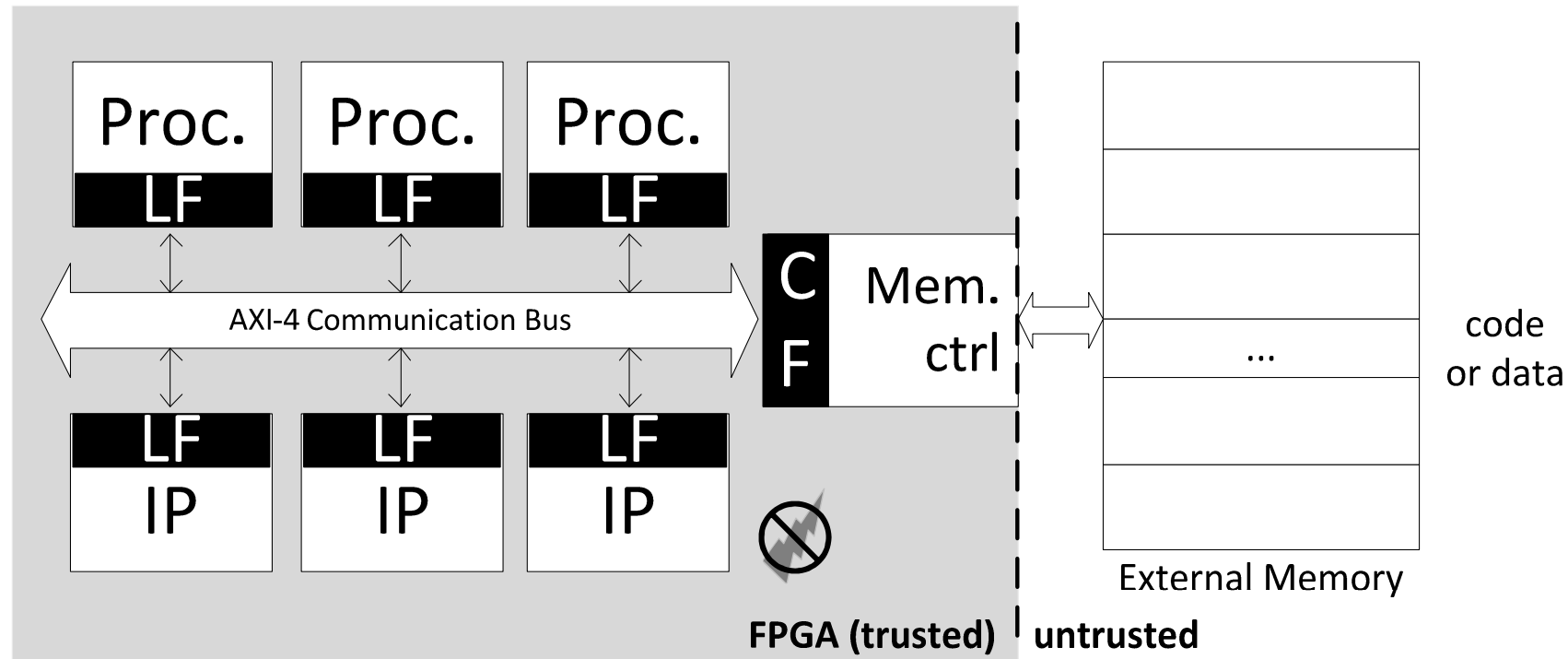

- Two kinds of interfaces :
 - Local Firewall (LF) for plaintext sections.
 - Cryptographic Firewall (CF) for DDR protection.

Static solution – Local Firewall (overv.)

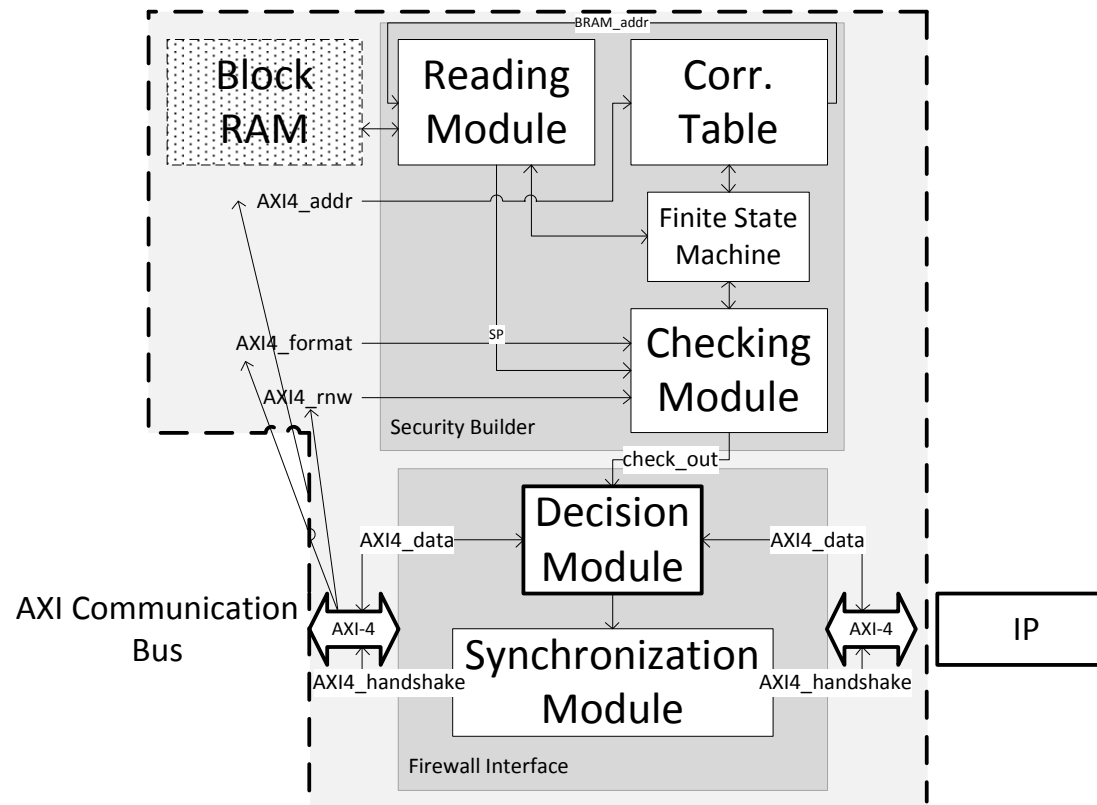

- Security rules storage in a Block RAM.
- Controls:
 - Address domains (memory mapping).
 - Read/Write accesses.
 - Allowed formats.

Static solution – Cryptographic Firewall

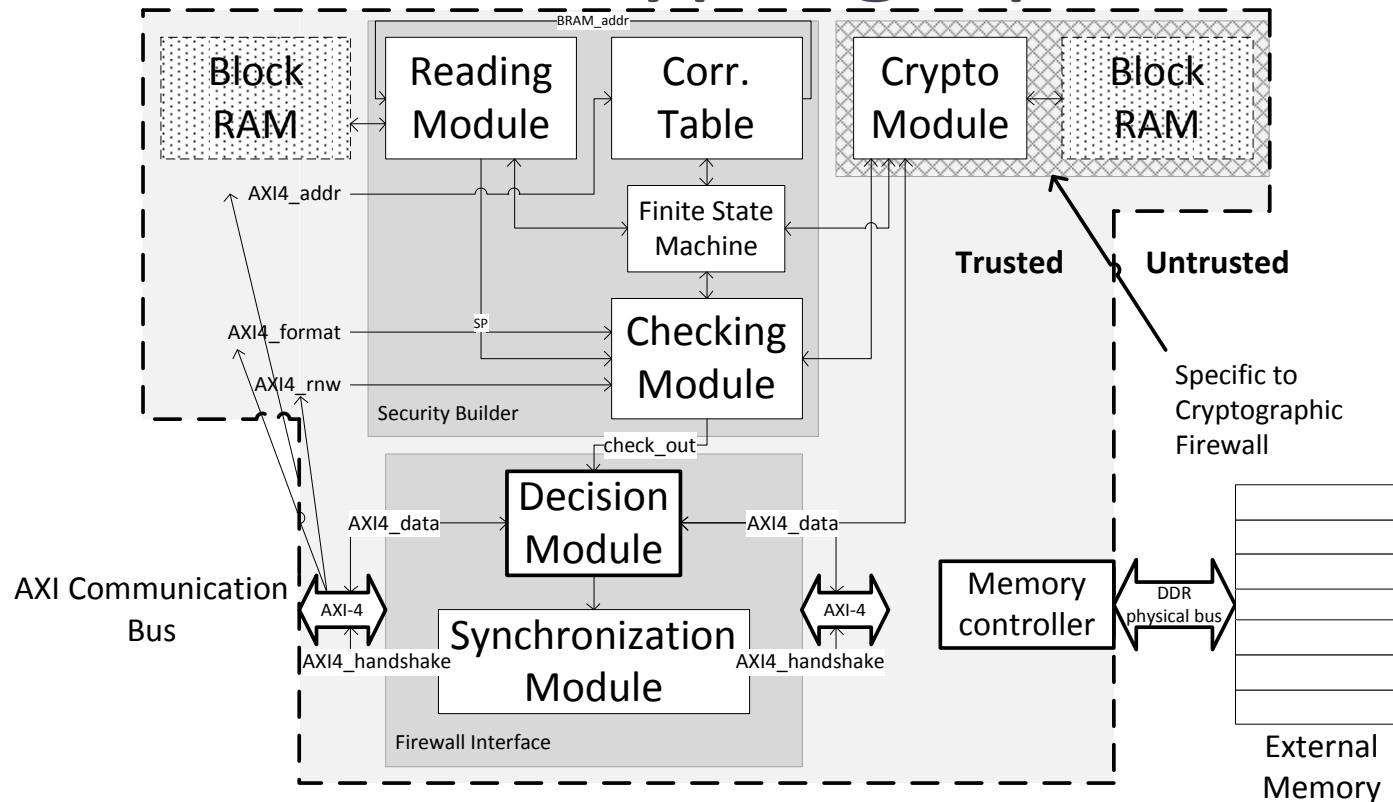

- Behavior similar to a Local Firewall.
- Crypto Module: flexible cipher/integrity functions.

Static solution – Cryptographic Firewall

**Ciphering of a 32-bit data block
(# of cycles)**

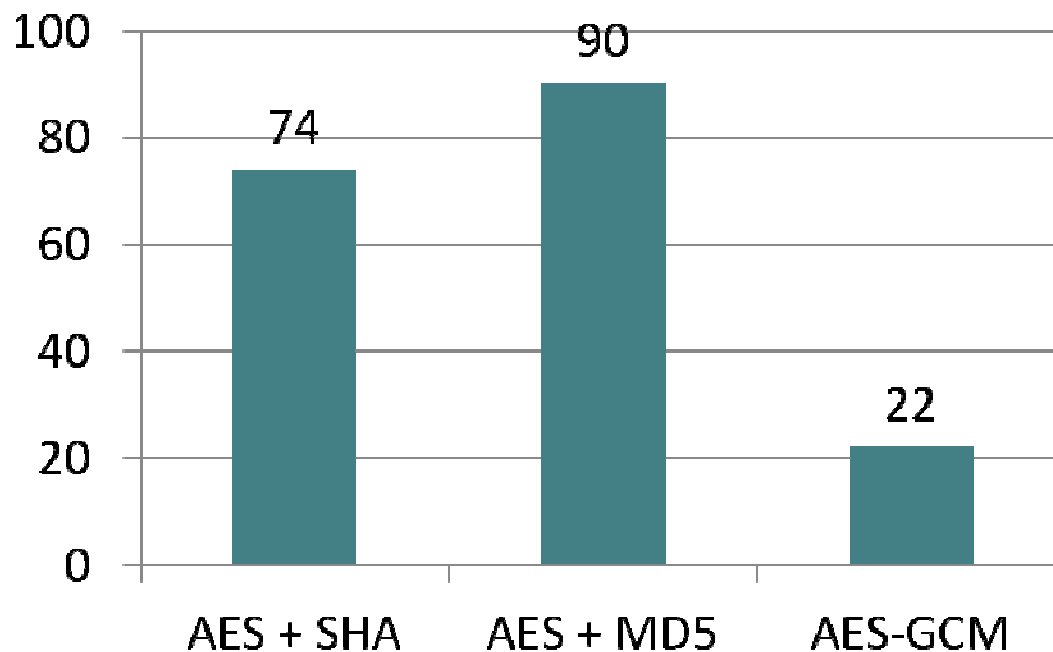

Crypto. algorithm (AES-GCM)

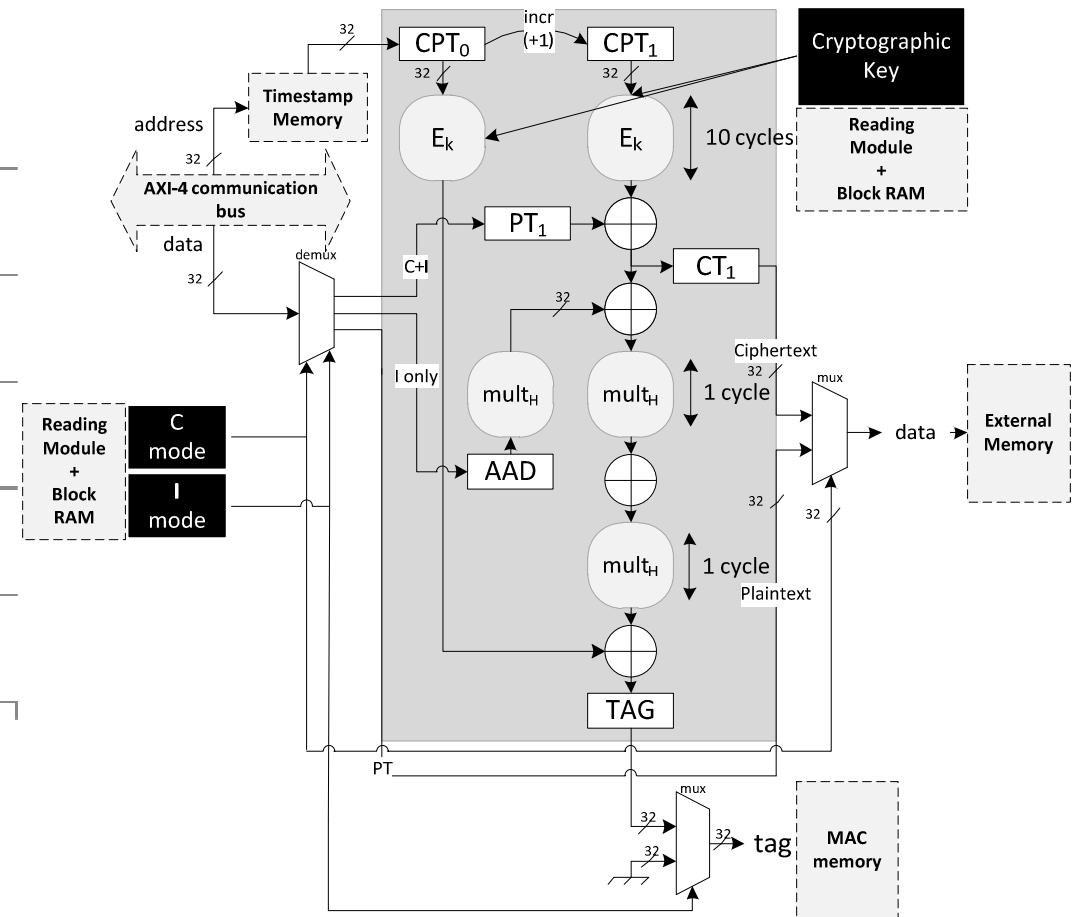

Static solution requirements

- **Internal** transactions metrics:
 - Read/Write rights.
 - Memory mapping.
 - Transaction formats.
- **External** transactions metrics:
 - Confidentiality.
 - Integrity.

Static solution requirements

- **Internal** transactions metrics:
 - ✓ Read/Write rights.
 - Memory mapping.
 - Transaction formats.
- **External** transactions metrics:
 - Confidentiality.
 - Integrity.

Static solution requirements

- **Internal** transactions metrics:
 - ✓ Read/Write rights.
 - ✓ Memory mapping.
 - Transaction formats.
- **External** transactions metrics:
 - Confidentiality.
 - Integrity.

Static solution requirements

- **Internal** transactions metrics:
 - ✓ Read/Write rights.
 - ✓ Memory mapping.
 - ✓ Transaction formats.

- **External** transactions metrics:
 - Confidentiality.
 - Integrity.

Static solution requirements

- **Internal** transactions metrics:
 - ✓ Read/Write rights.
 - ✓ Memory mapping.
 - ✓ Transaction formats.

- **External** transactions metrics:
 - ✓ Confidentiality.
 - Integrity.

Static solution requirements

- **Internal** transactions metrics:
 - ✓ Read/Write rights.
 - ✓ Memory mapping.
 - ✓ Transaction formats.

- **External** transactions metrics:
 - ✓ Confidentiality.
 - ✓ Integrity.

Summary of the static solution

- Flexible cryptography for the external memory.
- Protection against defined threat model even from plaintext sections.

Summary of the static solution

- Flexible cryptography for the external memory.
- Protection against defined threat model even from plaintext sections.
- What's next ?
 - How an attack is detected ?
 - How can we update security policies associated with each firewall ?

Adaptive solution

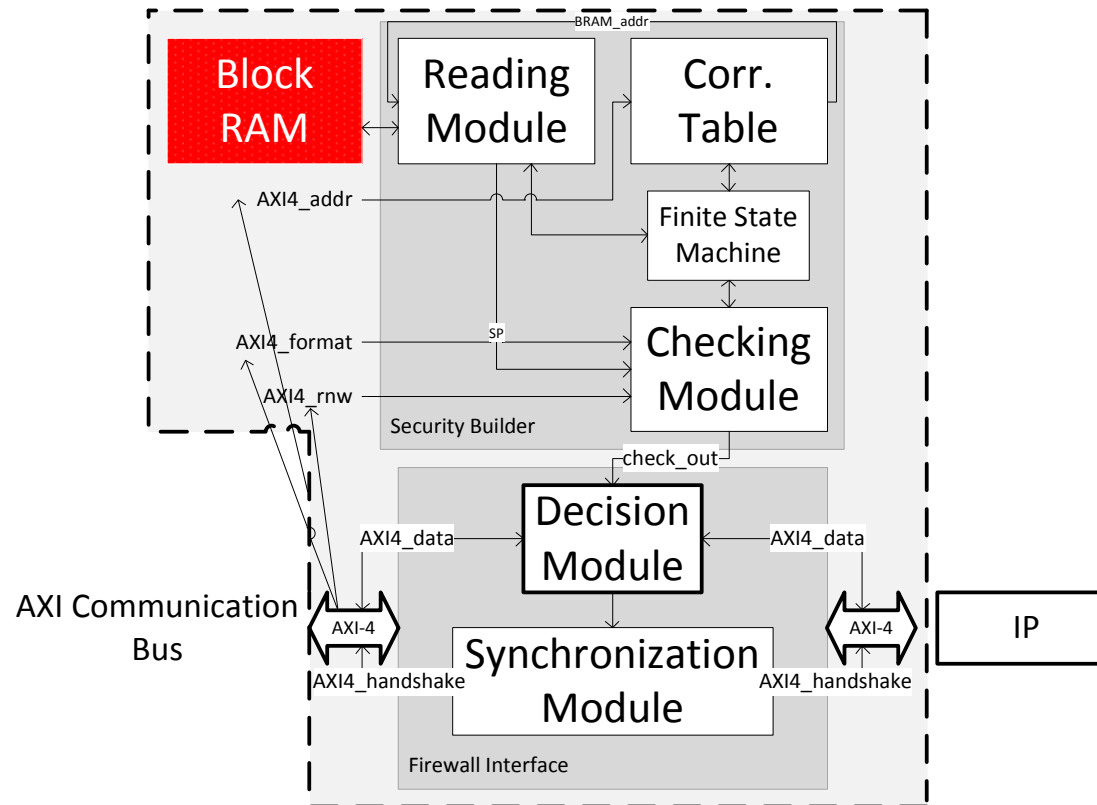

- Properties to be met:
 - Rights restriction.
 - IP isolation.
 - System reboot.

Adaptive solution

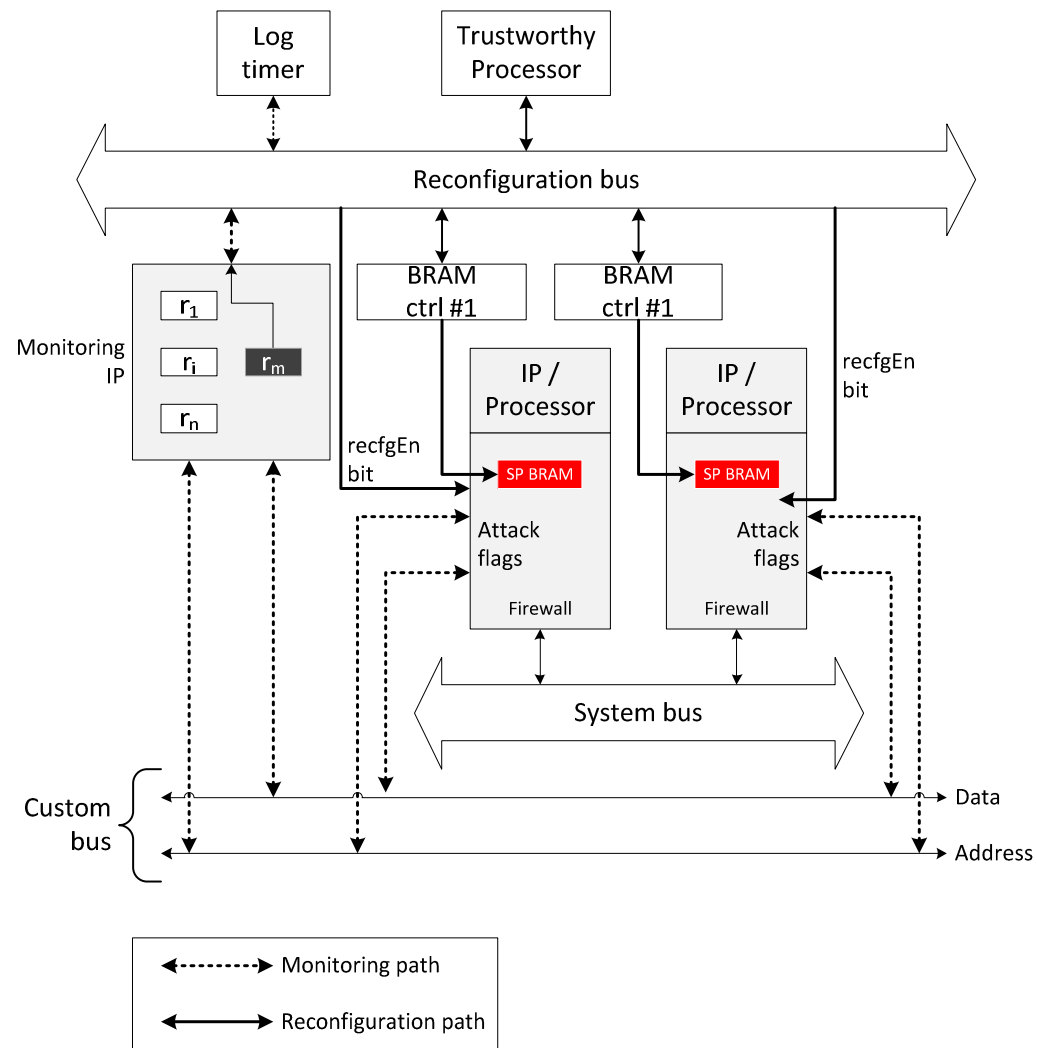

- Attacks monitoring.
- Block RAMs update (security policies, crypto parameters).
- Security-related events saved in a log file.

Monitoring IP

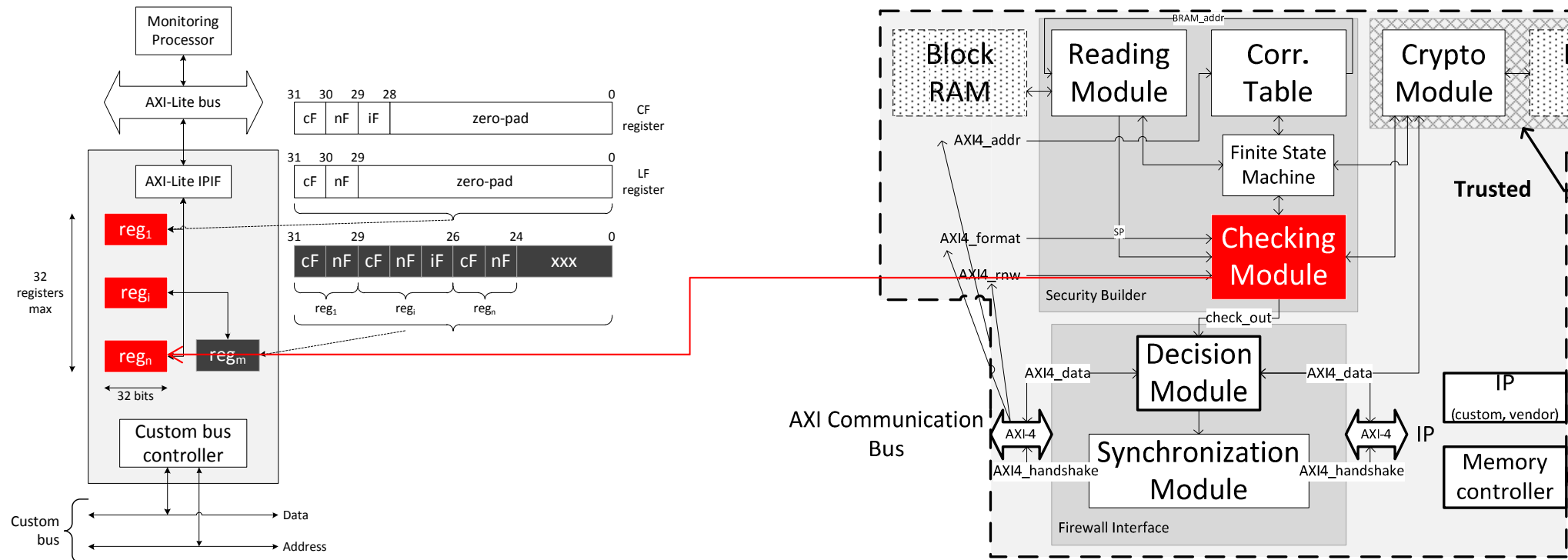

- Point-to-point between IP and firewall.
- Interruption launched when an attack is detected.

Runtime update

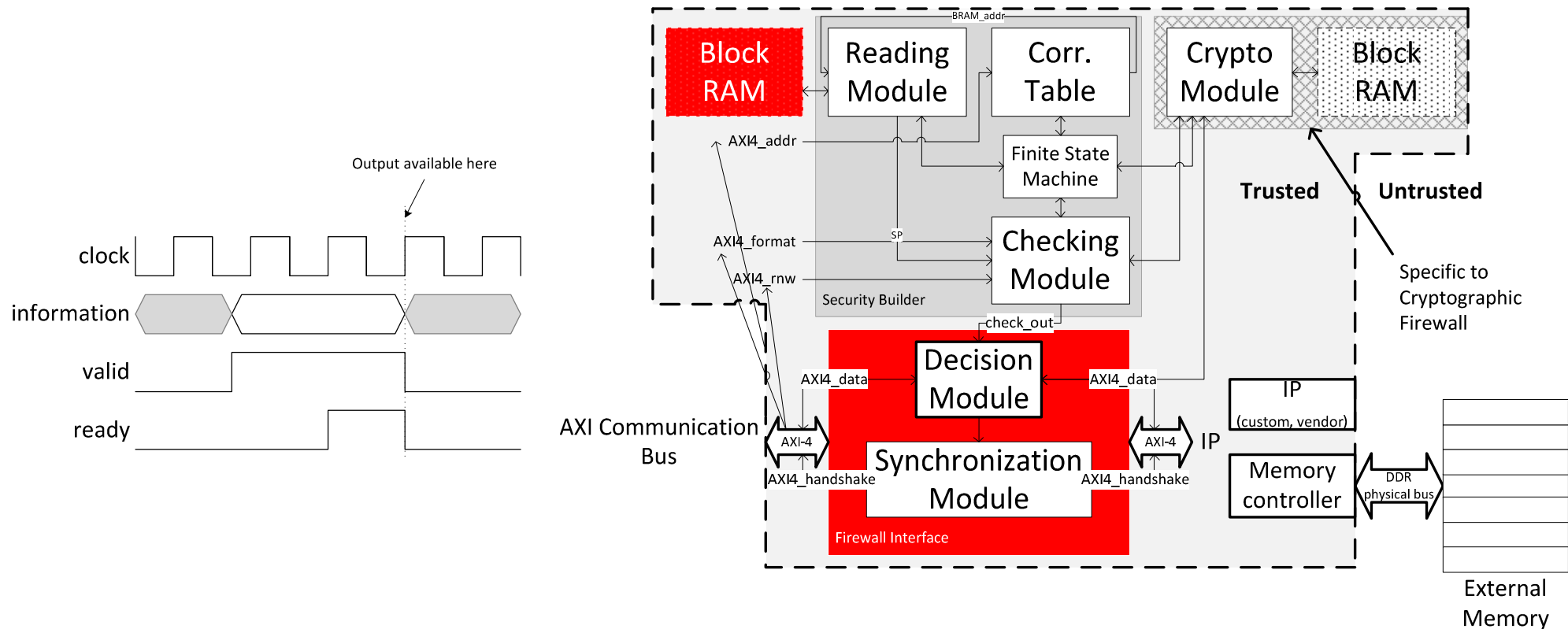

- Blocking incoming data.
- Uses AXI protocol features.
- Resuming when security update is finished.

Security policies evolution

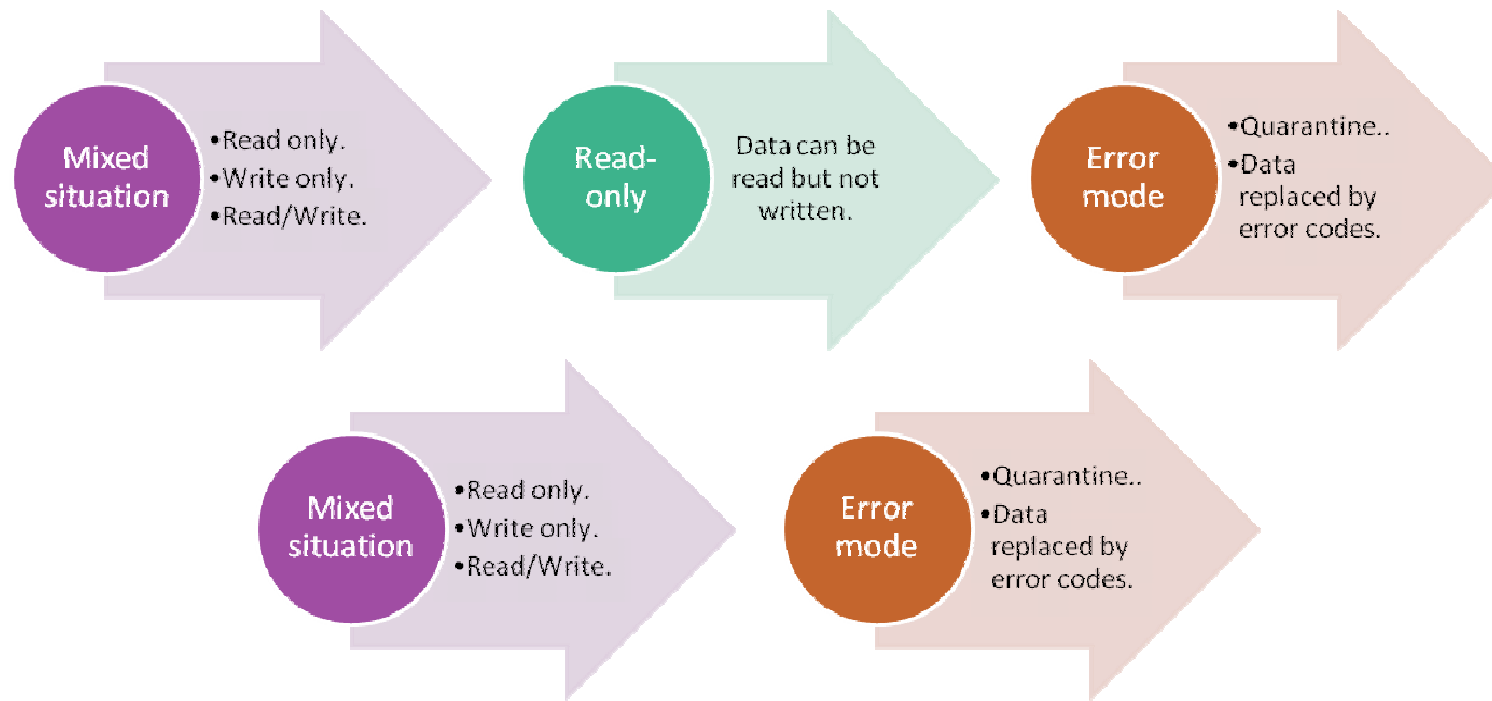

- Modifications of read/write rights only.
- Depending on user requirements.
- Critical case : system reboot (downloading the initial bitstream).

Summary of the adaptive solution

- Attacks monitoring.
- Update of security policies without malicious data leakage.
- Low-latency configuration of security Block RAMs.
- Evolution of security policies.
- Existing efforts:

	SECA	NoC + DPU	Our work
Comm. Topology	Bus	NoC	Bus
Crypto.	No	No	Yes
Update	No	Yes	Yes
Threat model	Wide range attacks	Buffer ov.	Wide range attacks

Implementation results

- Xilinx ML605 (Virtex-6).
- ISE Design Suite 13.4.

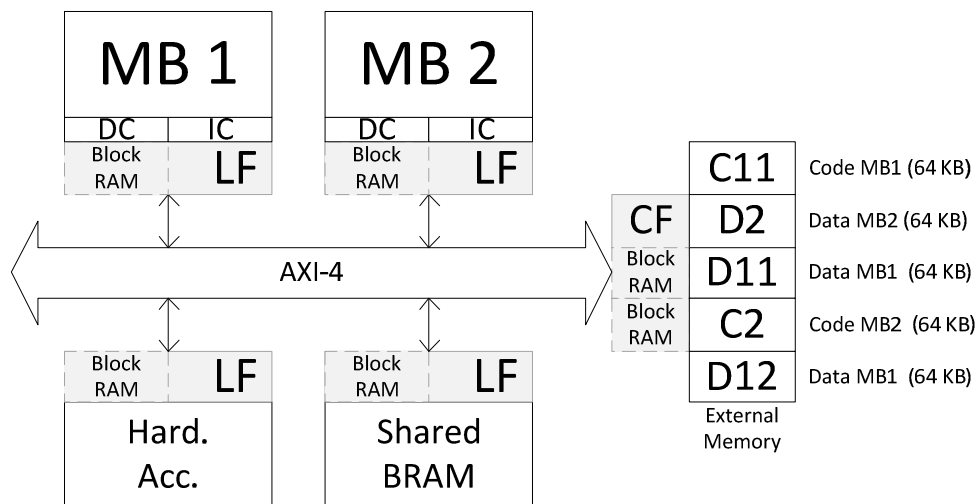

Crypto. parameters

	Crypto. mode
C11/D11	Conf. + integrity
D12	Integrity only
C12	Plaintext

Read/Write parameters

	BRAM	IP
MB1	Read only	Read/Write
MB2	Read/Write	Write only

Implementation results - Area

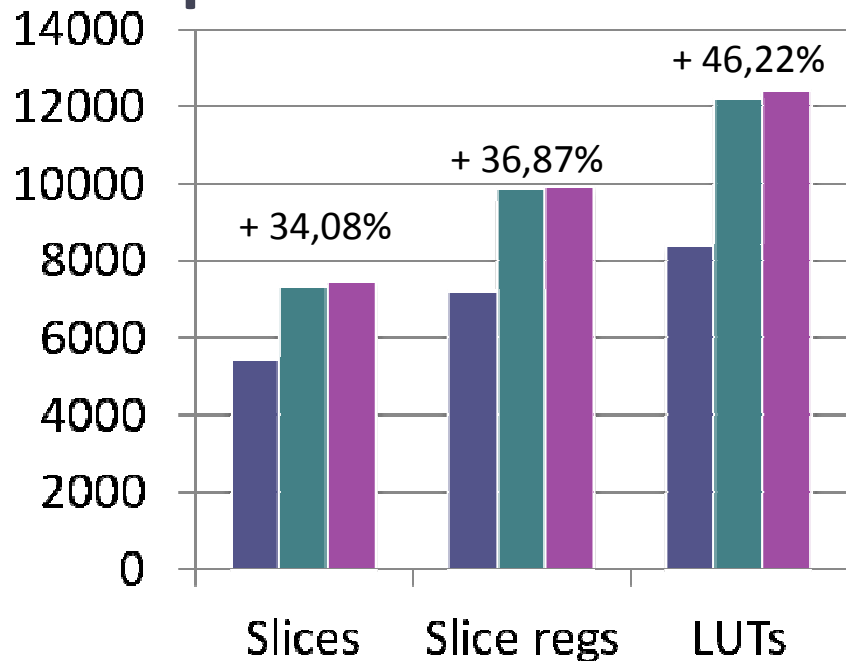

Overhead (%)

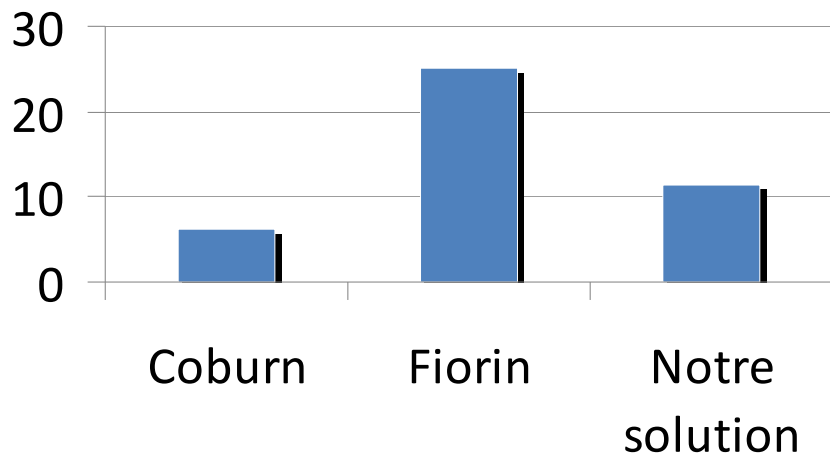

■ Unprotected
■ Statique
■ Configurable

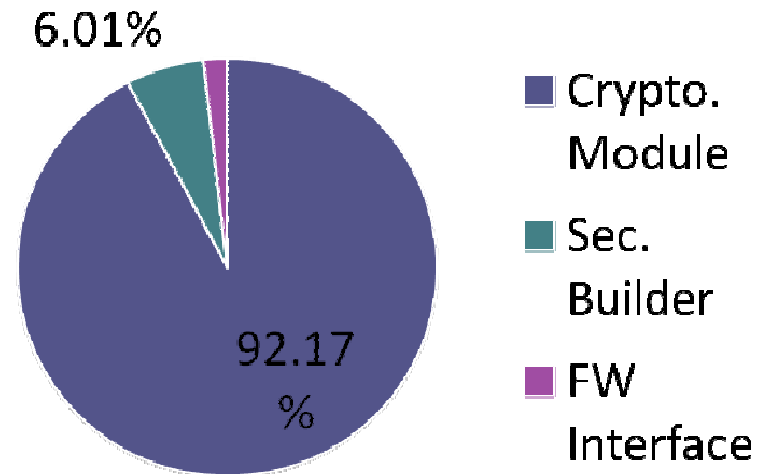

■ Crypto. Module
■ Sec. Builder
■ FW Interface

- Overhead of the configurable version is negligible.
- Area due to crypto.

Implementation results - Latency

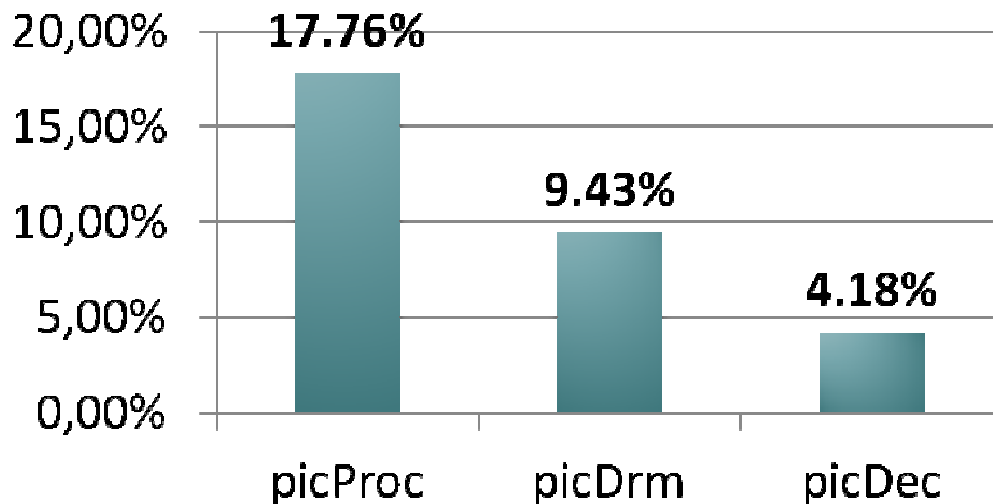

picProc: image processing on case study.

picDrm: DRM application.

picDec: software AES deciphering.

- Latency decrease: 33% compared to SECA approach (J. Coburn).

Conclusion on static/configurable solutions

- Static solution: low-latency solution based on hardware-only blocks.
- Runtime security update without data leakage.
- Acceptable area/latency trade-off.
- Compromise of existing works.

Self-reconfigurable security-enhanced communications in FPGA-based MPSoCs

Pascal Cotret, Laboratoire Lab-STICC
Université De Bretagne-Sud
<pascal.cotret@univ-ubs.fr>

Château de Goutelas, Marcoux
June 21st, 2012

